



HOSHIZAKI

CERTIFICATION



HACCP International



ISO9001



Compliant with IEC60335-2-89 Standard

FT-98MC-P-ST UNDERCOUNTER BAKERY REFRIGERATOR



Key Features



Lower running cost



Powerful cooling performance

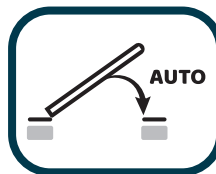

Self Closing Door



Removal door gaskets



Food Guard Shelf

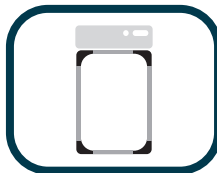

Round Interior Corners

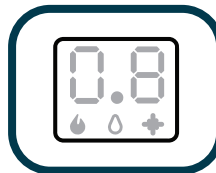

Large and clear display



Drainage-Free Design



Dimensions & Specifications

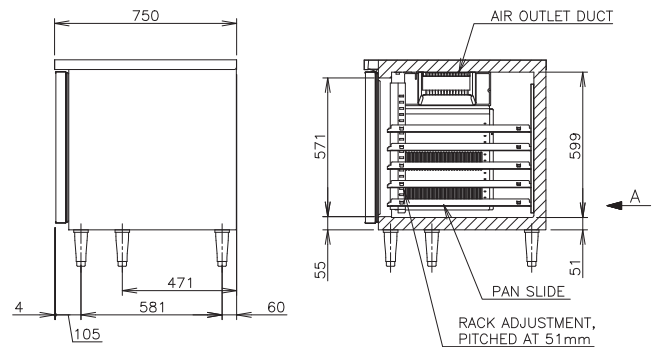
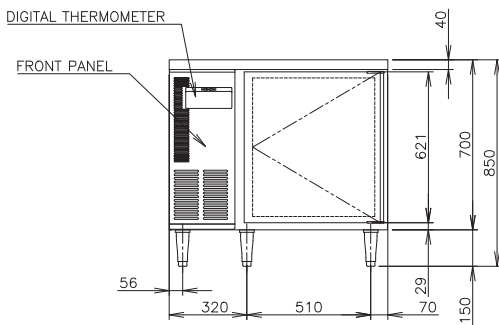
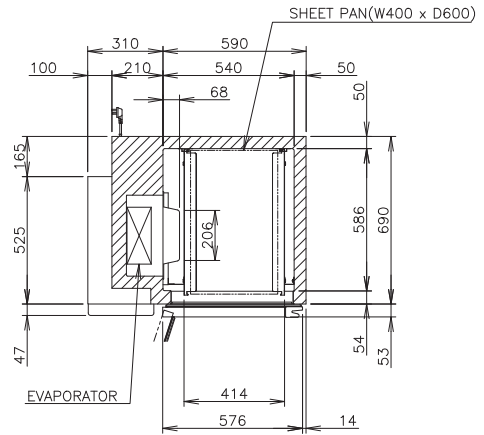
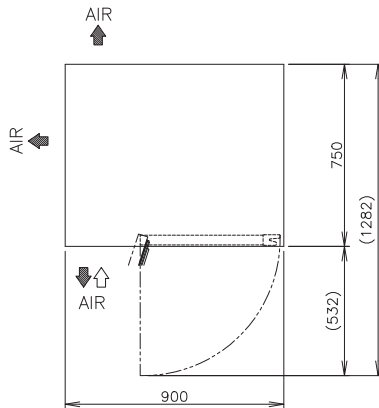
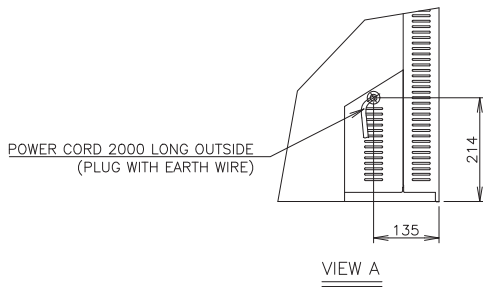

MODEL	FT-98MC-P-ST
POWER SUPPLY	1 Phase 230V 60Hz Capacity: 0.96kVA (4.20A)
ELECTRIC CONSUMPTION	238W
TEMPERATURE CONTROL	-6 to 12°C
STORAGE CAPACITY	197L
WEIGHT	Net: 68kg (Gross: Approx. 80kg)
OUTSIDE DIMENSIONS	900mm(W)× 750mm(D)×850(-880)mm(H)
PACKAGE	Carton 965mm(W)×830mm(D)×845mm(H)
NUMBER OF SHELVES	Tray Shelf (5 tiers)
REFRIGERANT	R290
OPERATING CONDITIONS	Ambient Temperature: 5 - 38°C, Voltage Range: Rated Voltage ±6%



HOSHIZAKI

HOSHIZAKI PHILIPPINES CORPORATION

Unit No. GB-2, G/F Agustin 1 Bldg., # 28 F. Ortigas Center, Pasig City,
Philippines 1605

TEL +632 8839 2861 <https://hoshizaki-sea.com/>

