



# HOSHIZAKI

## CERTIFICATION



HACCP International



ISO9001



Compliant with IEC60335-2-89 Standard

## FT-98MC-S-ST UNDERCOUNTER BAKERY REFRIGERATOR



### Key Features



Lower running cost



Powerful cooling performance

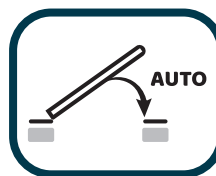

Self Closing Door



Removal door gaskets



Food Guard Shelf

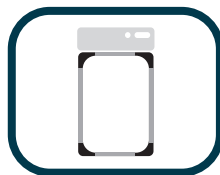

Round Interior Corners



Large and clear display



Drainage-Free Design



LED lighting



## Dimensions & Specifications

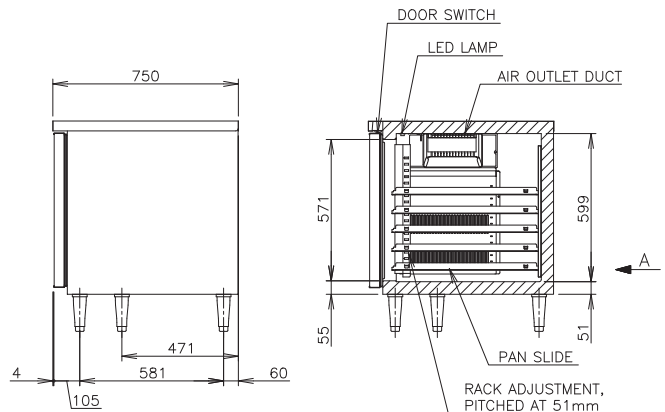
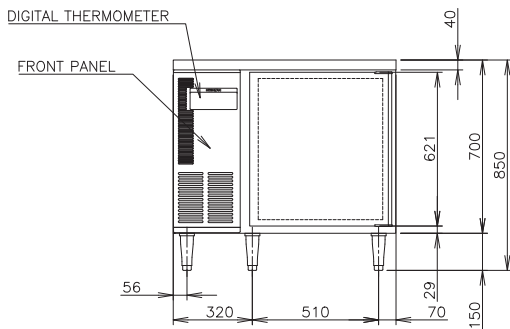
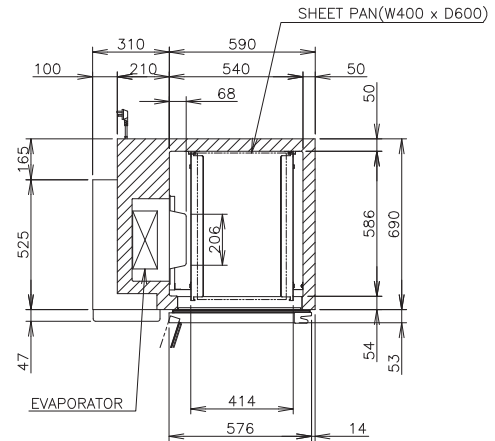
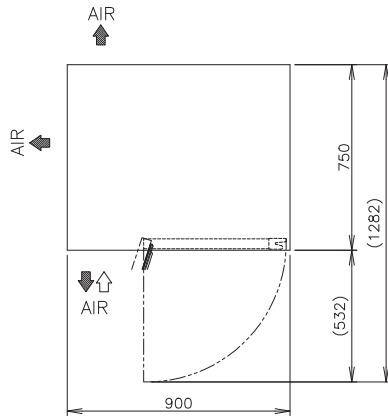
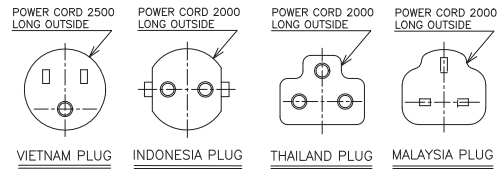
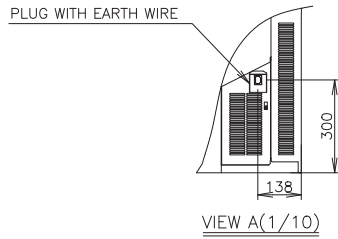

MODEL	FT-98MC-S-ST
POWER SUPPLY	1 Phase 220-240V 50Hz Capacity: 0.63kVA (2.90A)
ELECTRIC CONSUMPTION	209W
TEMPERATURE CONTROL	-6 to 12°C
STORAGE CAPACITY	197L
WEIGHT	Net: 68kg (Gross: Approx. 80kg)
OUTSIDE DIMENSIONS	900mm(W)× 750mm(D)×850(-880)mm(H)
PACKAGE	Carton 965mm(W)×830mm(D)×845mm(H)
NUMBER OF SHELVES	Tray Shelf (5 tiers)
REFRIGERANT	R290
OPERATING CONDITIONS	Ambient Temperature: 5 - 38°C, Voltage Range: Rated Voltage ±6%



# HOSHIZAKI

**HOSHIZAKI VIETNAM CORPORATION**

168/14 Nguyen Gia Tri, Thanh My Tay Ward, Ho Chi Minh City  
Vietnam 760000

TEL +84 0 916 161 346 <https://hoshizaki-sea.com/>

