



HOSHIZAKI

CERTIFICATION



HACCP International



ISO9001



Compliant with IEC60335-2-89 Standard

RT-126MC-P UNDERCOUNTER REFRIGERATOR



Key Features



Lower running cost



Powerful cooling performance

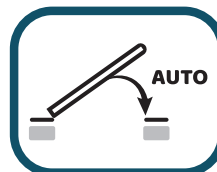

Self Closing Door



Removal door gaskets



Food Guard Shelf

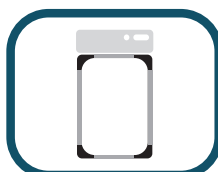

Round Interior Corners



Large and clear display

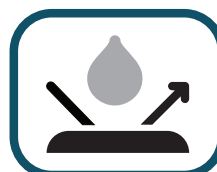

Drainage-Free Design



LED lighting



Dimensions & Specifications

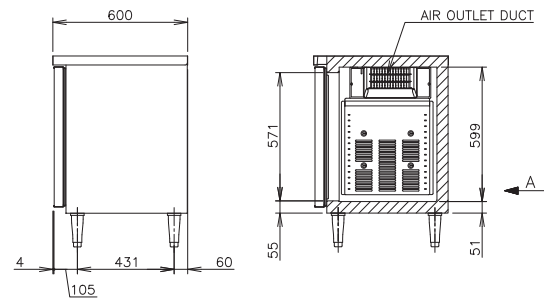
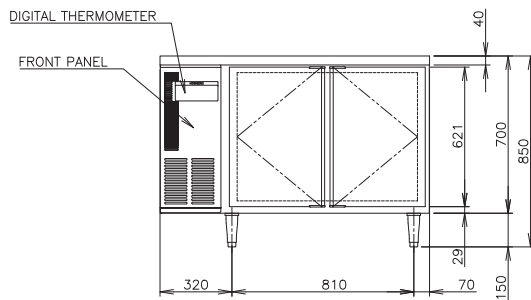
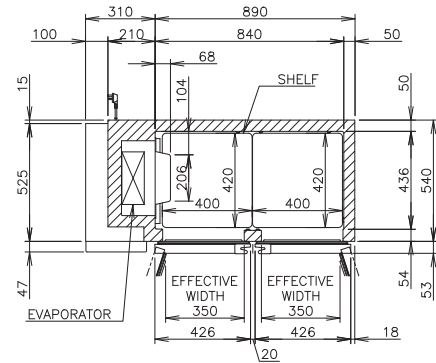
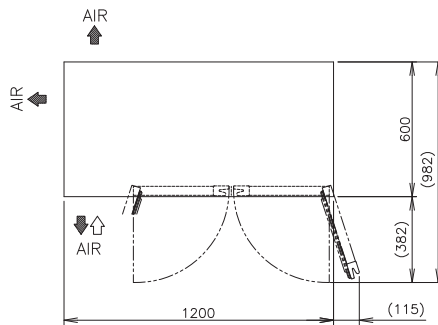
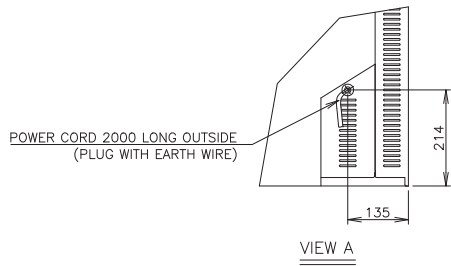

MODEL	RT-126MC-P
POWER SUPPLY	1 Phase 230V 60Hz Capacity: 0.71kVA (3.10A)
ELECTRIC CONSUMPTION	211W
TEMPERATURE CONTROL	-6 to 12°C
STORAGE CAPACITY	234L
WEIGHT	Net: 71kg (Gross: Approx. 83kg)
OUTSIDE DIMENSIONS	1200mm(W)× 600mm(D)×850(-880)mm(H)
PACKAGE	Carton 1265mm(W)×680mm(D)×790mm(H)
NUMBER OF SHELVES	4pcs
REFRIGERANT	R290
OPERATING CONDITIONS	Ambient Temperature: 5 - 38°C, Voltage Range: Rated Voltage ±6%



HOSHIZAKI

HOSHIZAKI PHILIPPINES CORPORATION

Unit No. GB-2, G/F Agustin 1 Bldg., # 28 F. Ortigas Center, Pasig City,
Philippines 1605

TEL +632 8839 2861 <https://hoshizaki-sea.com/>

