

VIEW A

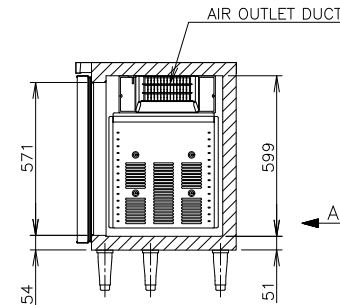

PHILIPPINES PLUG

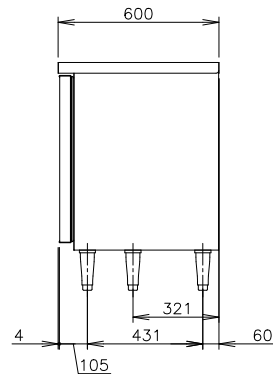
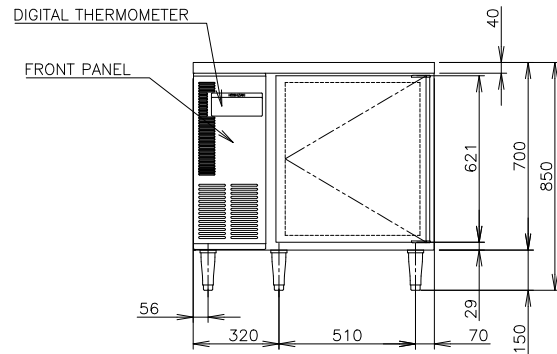
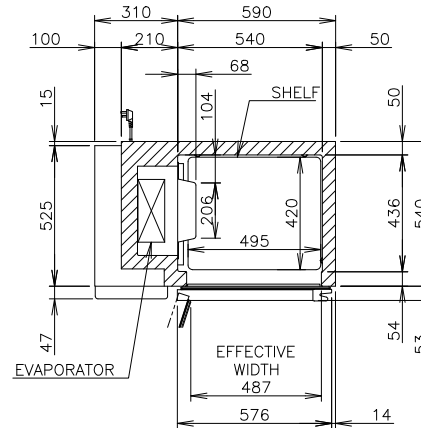
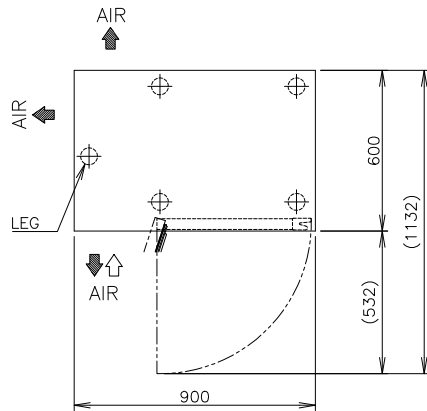

ITEM	Hoshizaki Undercounter Freezer
MODEL	FT-96MC-P
POWER SUPPLY	1 Phase 230V~ 60Hz Capacity: 0.96kVA (4.20A)
AMPERAGE	Rated 2.2A
ELECTRIC CONSUMPTION	Motor 219W(Power Factor 62%) Heater 209W Refrigeration 238W Defrost 190W
HEAT REJECTION	624W
POWER CORD	2.0m (Plug with Earth Wire)
EFFECTIVE CAPACITY	149L
OUTSIDE DIMENSIONS	900mm (W) x 600mm (D) x 850 (-880) mm (H)
INSIDE DIMENSIONS	540mm (W) x 436mm (D) x 599mm (H)
EXTERIOR	Stainless Steel, Galvanized Steel (Rear/Bottom)
INTERIOR	Stainless Steel, Stainless Pack(Door)
INSULATION	Polyurethane Foam
INSULATION FOAM BLOWING AGENT	Cyclopentane
REFRIGERATION SYSTEM	Forced Air Circulation
DEFROST SYSTEM	Glass Tube Heater
COMPRESSOR	Hermetic
CONDENSER	Fin and Tube type, Air-cooled
EVAPORATOR	Fin and Tube Type
REFRIGERANT	R290
TEMPERATURE CONTROL	Microprocessor controlled Adjustable from -25 to -7°C
DEFROST CONTROL	Microprocessor controlled
ELECTRIC CIRCUIT PROTECTION	Fuse, Earth Wire
COMPRESSOR PROTECTION	Motor Protector
LEG	Plastic Adjustable 150 to 180mm
SHELF	2pcs.
WEIGHT	Net:58kg (Gross: Approx. 70kg)
PACKAGE	Carton 965mm (W) x 680mm (D) x 845mm (H)
ACCESSORIES	-
OPERATING CONDITIONS	Ambient Temperature: 5-38°C Voltage Range: Rated Voltage±6%

\*We reserve the right to make changes in specifications and design without prior notice.

1. Install the product properly in accordance with the instructions on location, electrical connections stated in the instruction manual provided. Allow 10mm extra space at the installation site to meet any installation requirements (additional spacing is also required for proper air flow and pipe connections).
2. The heat rejection is based on the reached pull-down temperature at ambient temperature of 35°C and power supply of 230V 60Hz. The amperage and electric consumption are based on measurements at ambient temperature of 38°C and power supply of 230V 60Hz.
3. The cabinet temperature range of -25 to -7°C is guaranteed at ambient temperature of 30°C.
4. Product code: T438-C300