



---

UNDER COUNTER FREEZER

**FT-128MC**  
**FT-128MC-S**

# PARTS LIST

[HSH] [HS] [HHK]

T443,T443-V000,T443-C100

P-1 NOV. 2024  
Q-1 JAN. 2025  
Q-2 JUL. 2025  
Q-3 DEC.2025

Product Code	Spec
--------------	------

<b>FT-128MC</b>	
-----------------	--

<b>T443</b>	For HSH ; Standard
-------------	--------------------

<b>FT-128MC-S</b>	
-------------------	--

<b>T443-V000</b>	For HS;
------------------	---------

<b>T443-C100</b>	For HHK;
------------------	----------

## AUXILIARY CODE

### U - 1

The auxiliary code is the first two characters in the serial number. The first character indicates the production year. Years progress or regress in alphabetical order. The series of letters and skipped letters depend on UL listing, production, and model. See the auxiliary code(s) and corresponding year(s) on the front cover.

The second character indicates significant part changes within the same year. Base is "1" and this number advances for each change. If there is no significant part change at the turn of the year, this number starts from "0."

# FASTENER PART NUMBER

## SCREWS

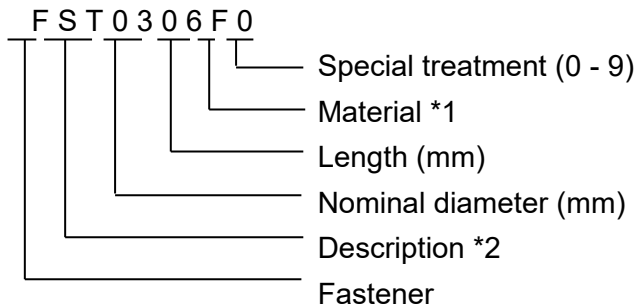

\*1

- F: Steel
- S: Austenitic stainless steel
- M: Martensitic stainless steel
- B: Copper alloy
- P: Polycarbonate
- N: Polyamide
- V: PVC
- A: ABS
- X: Polyacetal
- L: Aluminum

## NUTS & WASHERS

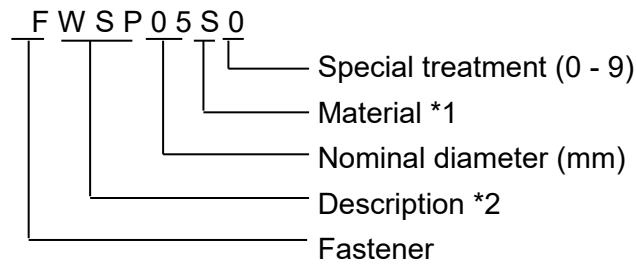

\*2

- First letter
- S: Machine screw
- T: Tapping screw
- M: Wood screw
- B: Bolt
- W: Washer
- N: Nut

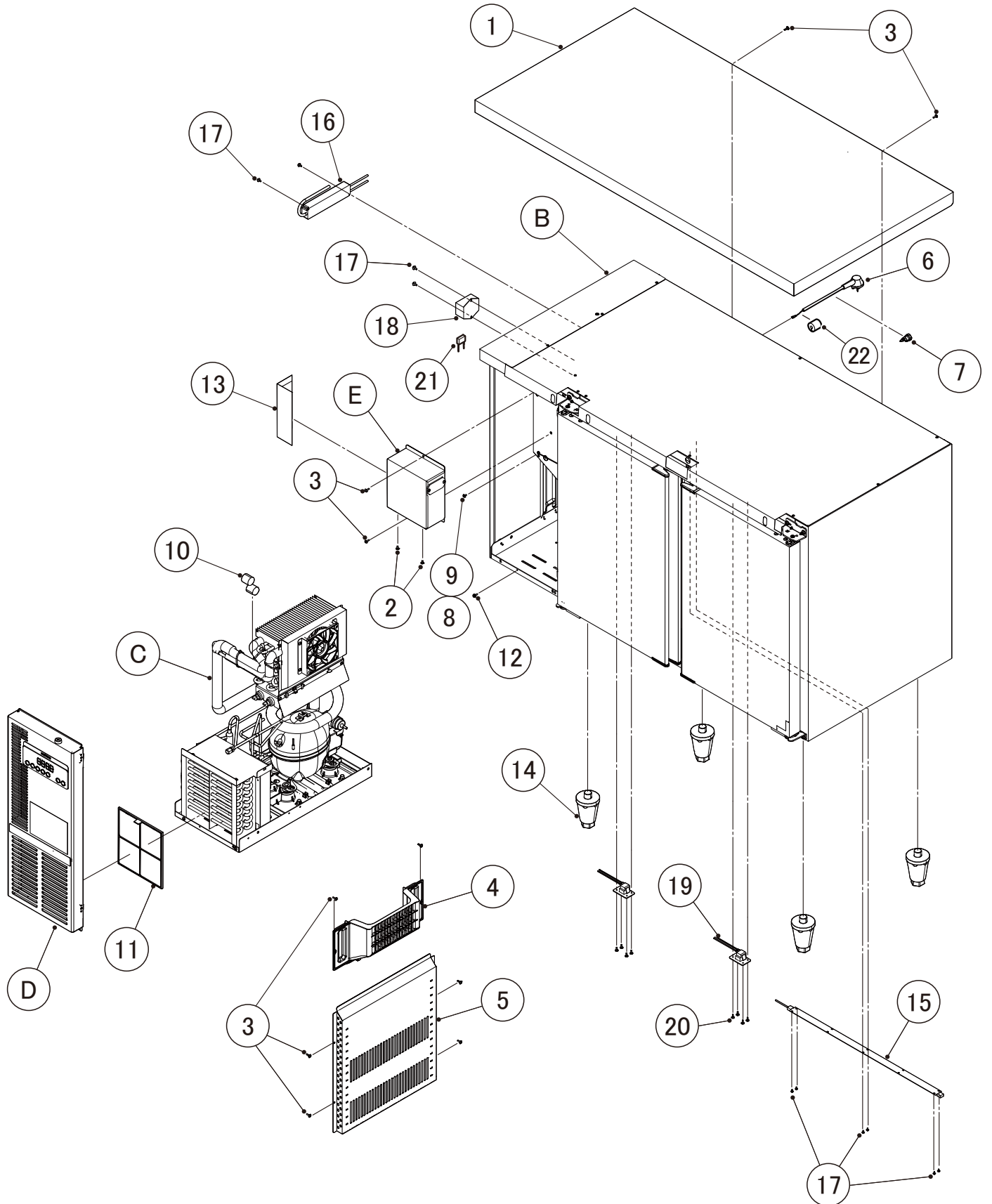

MODEL: FT-128MC(-S)

TITLE: A. REFRIGERATOR ASSY

INDEX NO.	DESCRIPTION	MATERIAL OR MODEL NUMBER	PART NUMBER	REQ'D NUMBER			
				P-1 Q-0	Q-1 and later		
B	BODY AY	T443	1C1268A02	1	1		
		T443-V000	1C0943A02	-	1		
		T443-C100	1C0943005	-	1		
C	REFRIGERATION UNIT		1C0787A01	1	1		
D	FRONT PANEL AY	T443	3C1111A01	1	1		
		T443-V000 T443-C100	3C1111A02	-	1		
E	CONTROL BOX AY	T443	2C1283A02	1	1		
		T443-V000	2C1283A04	-	1		
		T443-C100	2C1283A10	-	1		
L	LABEL LOCATION		-	1	1		
M	ACCESSORIES		-	1	1		
1	TOP PANEL		2C1543M04	1	1		
2	T2 TRUSS HEAD SCREW		FT20408M0	2	2		
3	TRUSS HEAD TAPPING SCREW T1		FT10412M0	11	11		
4	DUCT A	T443 T443-C100	1R2770P01	1	1		
	DUCT	T443-V000	1C0469G01	-	1		
5	DUCT B		3S3562G02	1	1		
6	POWER SUPPLY CORD - ASSY	(S-21669) T443	3S0665G01	1	1		
		(S-22054) T443-C100	3S1891G01	-	1		
7	BUSHING	T443 T443-C100	448949-01	1	1		
8	SPRING WASHER		FWSP04S0	2	2		
9	TRUSS HEAD SCREW		FST0408S0	2	2		
10	INSULATION		4R5835Z01	2	2		
11	AIR FILTER		390731G01	1	1		
12	HEX HEAD BOLT SW	T443	FBK0412S0	1	1		
	THUMBSCREW	T443-V000 T443-C100	428833-01	-	1		

MODEL: **FT-128MC(-S)**TITLE: **A. REFRIGERATOR ASSY**

INDEX NO.	DESCRIPTION	MATERIAL OR MODEL NUMBER	PART NUMBER	REQ'D NUMBER			
				P-1 Q-0	Q-1 and later		
13	COVER - CONTROL BOX		4C0293P01	1	1		
14	LEG	T443	P04879-01	4	4		
15	LED LAMP	T443-V000	P05001-03	-	1		
16	SWITCHING REGULATOR	T443-V000	P05002-01	-	1		
17	PAN HEAD SCREW SW	T443-V000	FSK0308S0	-	10		
18	NOISE FILTER	T443-V000	3C0369G01	-	1		
19	DOOR SWITCH	T443-V000 T443-C100	3C2054G01	-	2		
20	S-TITE TRUSS HEAD SCREW	T443-V000 T443-C100	FTS0406M0	-	8		
21	CAPACITOR	T443-C100	P00228-01	-	1		
22	FERRITE CORE	T443-C100	C06018-01	-	1		



MODEL: **FT-128MC(-S)**TITLE: **B. BODY AY**

INDEX NO.	DESCRIPTION	MATERIAL OR MODEL NUMBER	PART NUMBER	REQ'D NUMBER			
				P-1 Q-0	Q-1 and later		
F	DOOR L, AY	(S-30203) T443	274431A04	1	1		
		T443-V000 T443-C100	274431A07	-	1		
G	DOOR R,AY	(S-30204) T443	274432A04	1	1		
		T443-V000 T443-C100	274432A08	-	1		
1	BODY	T443	1C1269G02	1	1		
		T443-V000	1C0942G02	-	1		
		T443-C100	1C0942005	-	1		
2	DOOR HINGE (L) , LO		375319G01	1	1		
3	FLANGE BOLT (S-TITE)		P02005-01	8	8		
4	DOOR HINGE (L) , UP		375318G01	1	1		
5	DOOR HINGE (R) , LO		375316G01	1	1		
6	DOOR HINGE (R) , UP		375315G01	1	1		
7	HINGE COLLAR - HINGE		339948-01	2	2		
8	BASE		277850M05	1	1		
9	FLANGE BOLT (S-TITE)		FTQ0512F0	2	2		
10	BRACKET - TOP PANEL		2R5585M02	1	1		
11	FRAME - UNIT		3S2838M01	1	1		
12	LOUVER - UNIT	T443 T443-C100	389439M01	1	1		
		T443-V000	3C0368G01	-	1		
13	T2 TRUSS HEAD SCREW		FT20408M0	6	6		
14	PVC HOSE		HA1821380	1	1		
15	CLAMP		463936-01	1	1		
16	SIDE PANEL - UNIT		2R5741M02	1	1		
17	BRACKET B - TOP PANEL		2R5881M02	1	1		

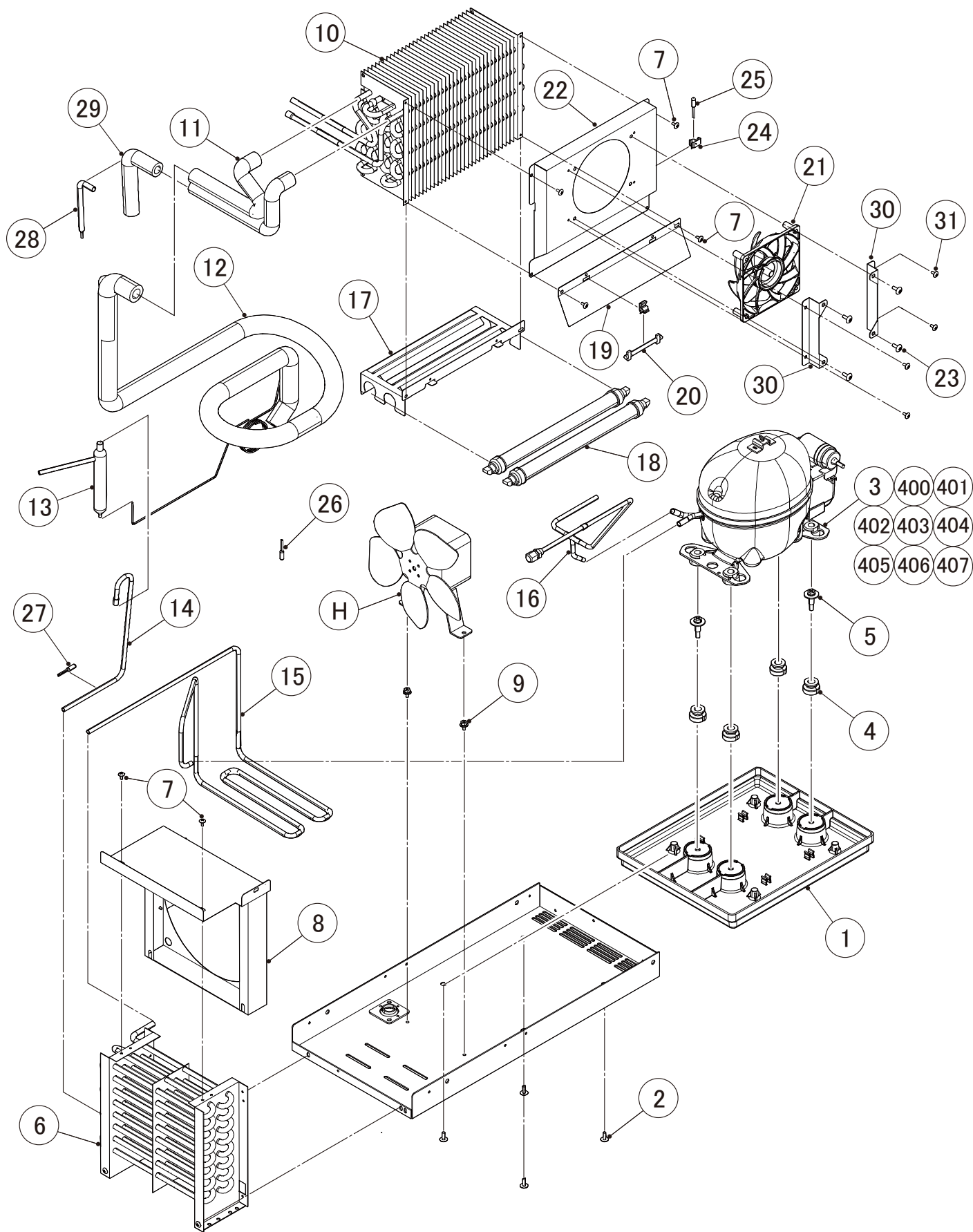



MODEL: **FT-128MC(-S)**TITLE: **C. REFRIGERATION UNIT**

INDEX NO.	DESCRIPTION	MATERIAL OR MODEL NUMBER	PART NUMBER	REQ'D NUMBER			
				P-1 Q-1	Q-2 and later		
H	FAN MOTOR AY		3S0697A02	1	1		
1	DRAIN PAN		280721P01	1	1		
2	TRUSS HEAD SCREW		FST0512S0	4	4		
3	COMPRESSOR		P06646-01	1	1		
4	GROMMET		450897-01	4	4		
5	BOLT		C05825-01	2	2		
6	CONDENSER		P02101-01	1	1		
7	T2 TRUSS HEAD SCREW		FT20408M0	7	7		
8	SHROUD		3S3339G01	1	1		
9	HEX HEAD BOLT (SPRING WASHER AND FLAT WASHER)		FBK0510S0	2	2		
10	EVAPORATOR		C07252-01	1	1		
11	INSULATION TUBE		H71323260	2	2		
12	HEAT EXCHANGER		2C1294G01	1	1		
13	DRIER		C06620-01	1	1		
14	PIPE A		486018M01	1	1		
15	PIPE-DISCHARGE		3C1110G01	1	1		
16	COPPER TUBE (L)		3C1098G01	1	1		
17	COVER - HEATER		2C1280M01	1	1		
18	HEATER-GLASS TUBE		C06573-01	2	2		
19	HEATER BRACKET		3S3049M01	1	1		
20	FUSE		P04976-01	1	1		
21	FAN MOTOR		C07478-01	1	1		
22	EVAP COVER		2C1875M01	1	1		
23	T2 TRUSS HEAD SCREW		FT20512S0	4	4		
24	CLIP-FUSE		4R2937-01	2	2		
25	TERMISTOR	白 除霜用 1.5M	C06414-01	1	1		
26	TERMISTOR	黒 庫内用 1.5M	C06414-02	1	1		
27	TERMISTOR	灰 凝縮器用 1.5M	C06414-03	1	1		

MODEL: **FT-128MC(-S)**TITLE: **C. REFRIGERATION UNIT**

INDEX NO.	DESCRIPTION	MATERIAL OR MODEL NUMBER	PART NUMBER	REQ'D NUMBER			
				P-1 Q-1	Q-2 and later		
28	PIPE A - EVAPORATOR		4C0573M01	1	1		
29	INSULATION TUBE		H71323150	1	1		
30	BRACKET		4C0850M01	2	-		
31	TRUSS HEAD SCREW		FST0408S0	4	-		
400	RELAY COVER		P07088-01	1	1		
401	CABLE FASTENER		P07183-01	1	1		
402	SCREW		P07184-01	1	1		
403	OVERLOAD PROTECTOR		P07347-01	1	1		
404	PTC RELAY		P07348-01	1	1		
405	FULL ALL CAP		P07545-01	1	1		
406	CAPACITOR HOLDER		P06401-01	1	1		
407	RUBBER BAND BLACK		P07351-01	1	1		

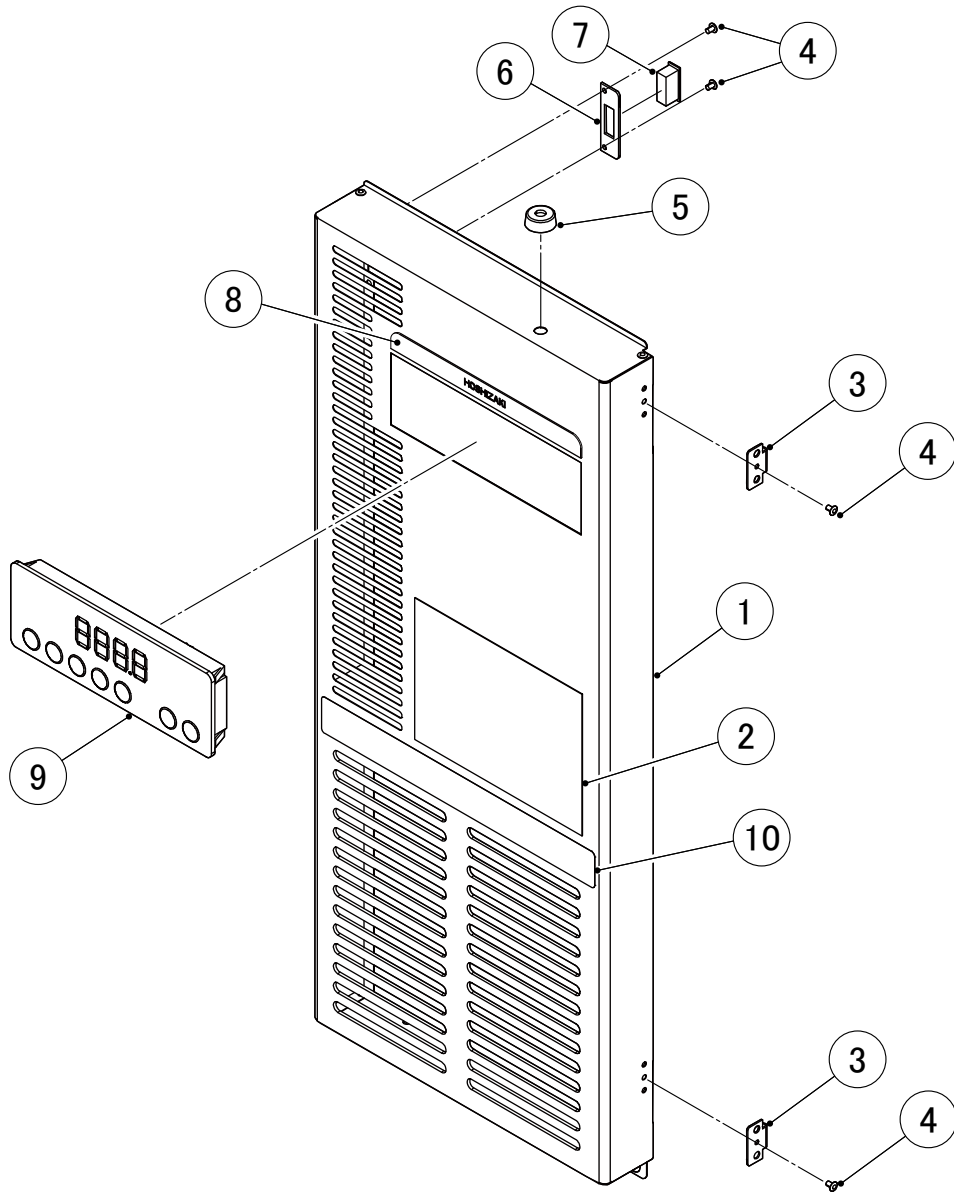

MODEL: **FT-128MC(-S)**

TITLE: **D. FRONT PANEL AY**

INDEX NO.	DESCRIPTION	MATERIAL OR MODEL NUMBER	PART NUMBER	REQ'D NUMBER			
				P-1 Q-0	Q-1 and later		
1	FRONT PANEL		2C1295G01	1	1		
2	INSTRUCTION LABEL	T443	391442L01	1	1		
3	HINGE B		4R2858-01	2	2		
4	RIVET		7170-0201	4	4		
5	PLASTI FOOT		456673-01	1	1		
6	SUPPORT - MAGNET		484969M01	1	1		
7	MAGNET CATCH		4R2838-01	1	1		
8	FRONT PANEL LABEL		4C0554L01	1	1		
9	CONTROLLER DISPLAY		C06539-01	1	1		
10	PL LABEL-AIR FILTER	T443-V000 T443-C100	373397L01	-	1		

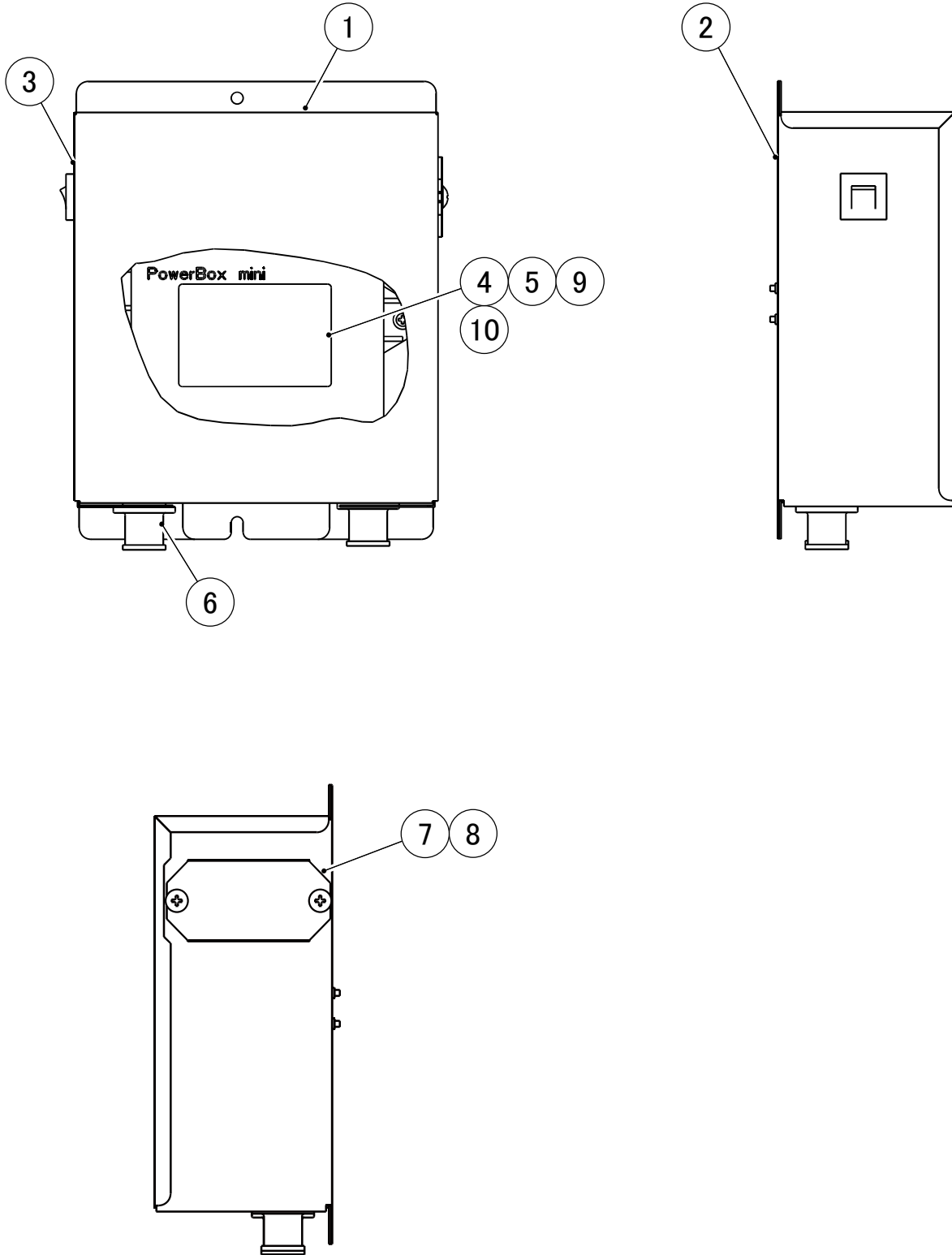

MODEL: **FT-128MC(-S)**

TITLE: **E. CONTROL BOX AY**

INDEX NO.	DESCRIPTION	MATERIAL OR MODEL NUMBER	PART NUMBER	REQ'D NUMBER			
				P-1 Q-0	Q-1 and later		
1	CONTROL BOX B		2C1284M01	1	1		
2	CONTROL BOX A		2C1285M02	1	1		
3	PROTECTOR		440972-07	1	1		
4	CONTROLLER		C06540-01	1	1		
5	HARNESS - CONTROLLER		C06580-01	1	1		
6	GROMMET		4H2568-02	2	2		
7	POWER RELAY		C06306-01	1	1		
8	T2 TRUSS HEAD SCREW		FT20408M0	2	2		
9	HARNESS - CONTROL BOX AY	T443	3C1462G02	1	1		
		T443-V000	3C1462G04	-	1		
		T443-C100	3C1462G10	-	1		
10	PAN HEAD SCREW SW		431415-01	2	2		

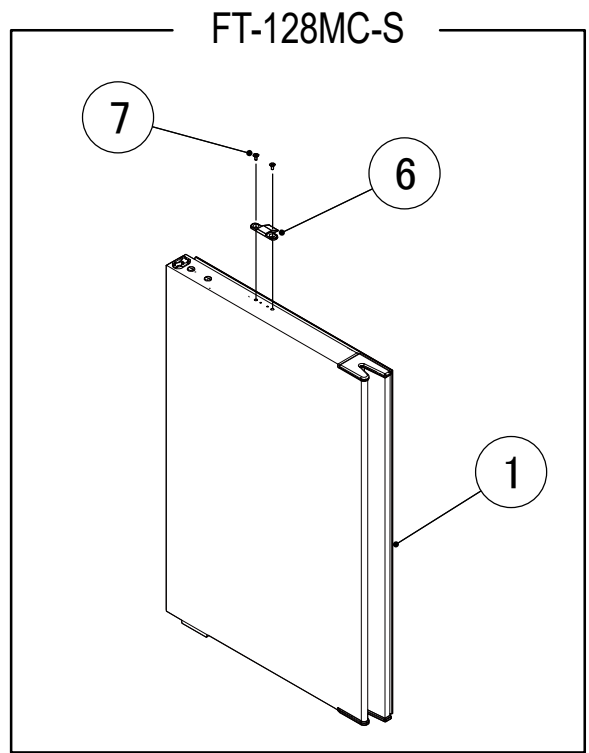
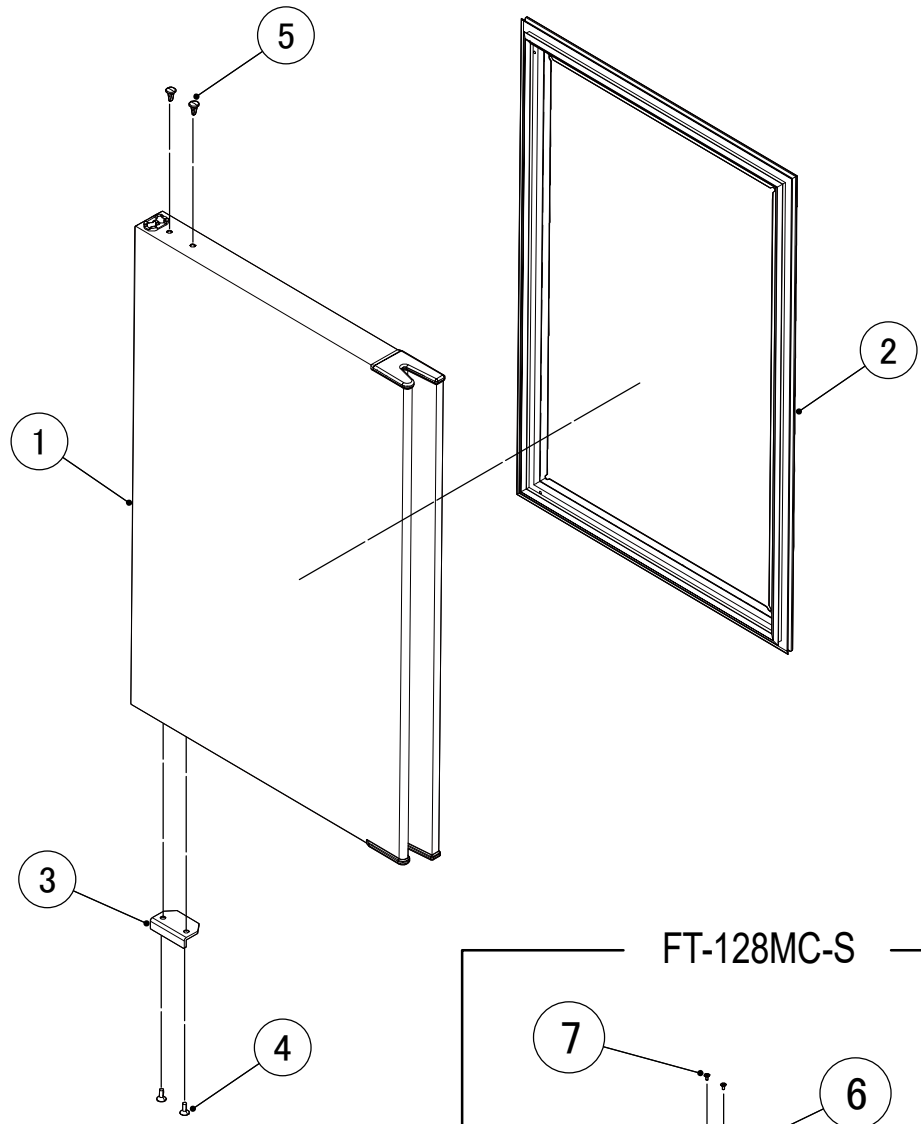

MODEL: **FT-128MC(-S)**

TITLE: **F. DOOR L, AY**

INDEX NO.	DESCRIPTION	MATERIAL OR MODEL NUMBER	PART NUMBER	REQ'D NUMBER			
				P-1 Q-0	Q-1 and later		
1	DOOR - INSULATION	T443	274094G04	1	1		
		T443-V000 T443-C100	274094G08	-	1		
2	DOOR GASKET		2R5297G01	1	1		
3	DOOR STOPPER		454210-01	1	1		
4	FLAT HEAD TAPPING SCREW (S-TITE)		FTF0512M0	2	2		
5	HOLE PLUG		463980-01	2	2		
6	DOOR STOPPER	T443-V000 T443-C100	4C0673P01	-	1		
7	FLAT HEAD MACHINE SCREW	T443-V000 T443-C100	FSF0408S0	-	2		

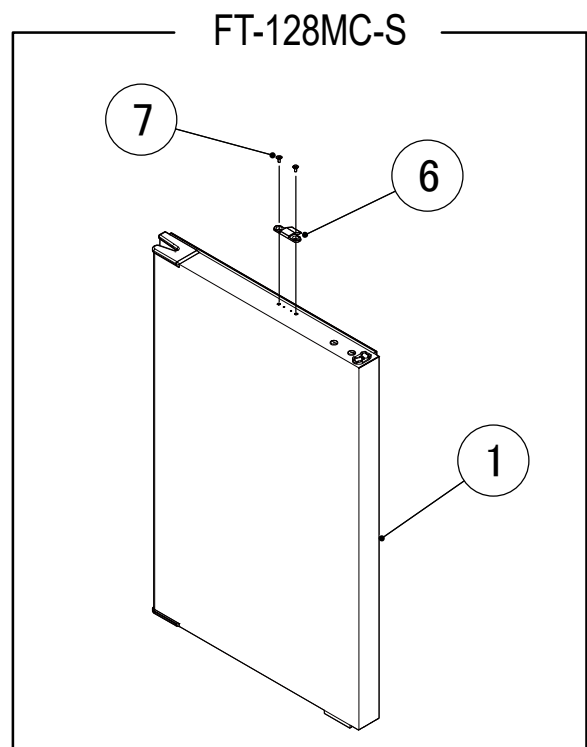
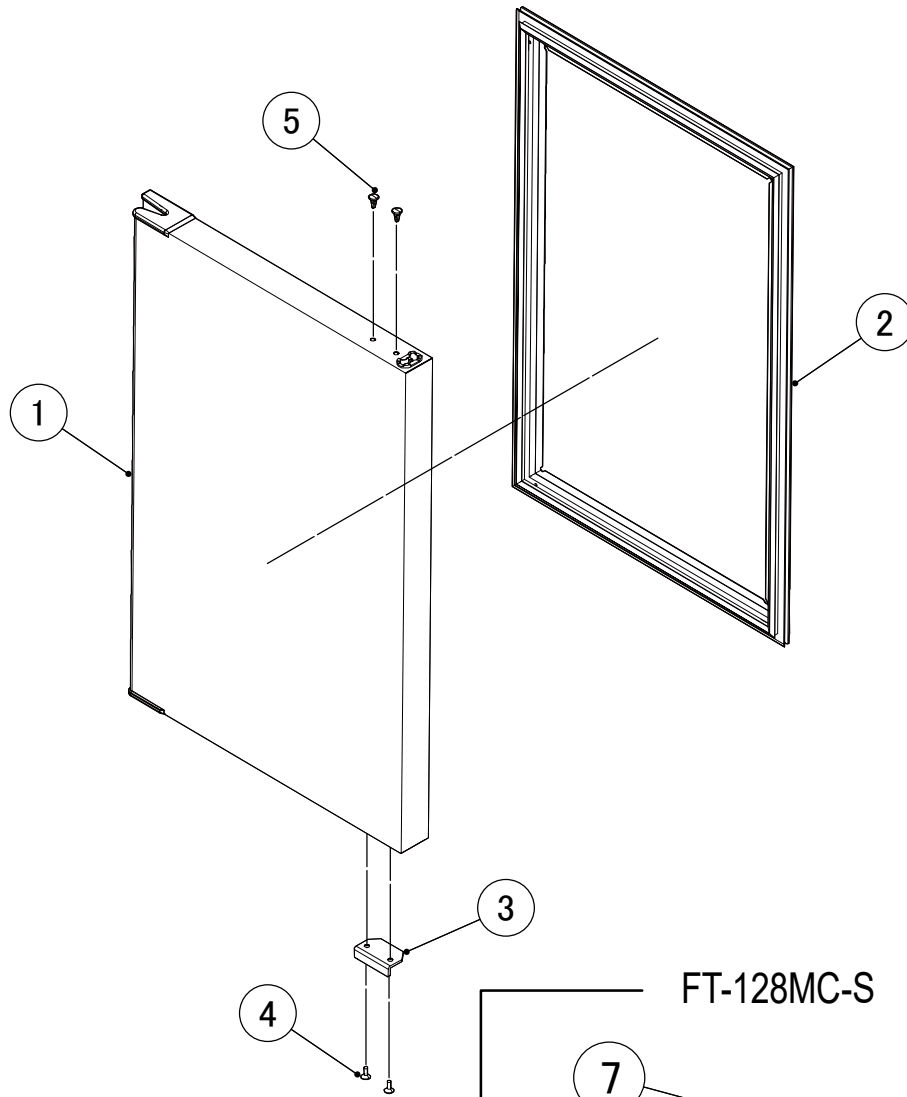

MODEL: **FT-128MC(-S)**

TITLE: **G. DOOR R, AY**

INDEX NO.	DESCRIPTION	MATERIAL OR MODEL NUMBER	PART NUMBER	REQ'D NUMBER			
				P-1 Q-0	Q-1 and later		
1	DOOR - INSULATION	T443	274094G04	1	1		
		T443-V000 T443-C100	274094G08	-	1		
2	DOOR GASKET		2R5297G01	1	1		
3	DOOR STOPPER		454210-01	1	1		
4	FLAT HEAD TAPPING SCREW (S-TITE)		FTF0512M0	2	2		
5	HOLE PLUG		463980-01	2	2		
6	DOOR STOPPER	T443-V000 T443-C100	4C0673P01	-	1		
7	FLAT HEAD MACHINE SCREW	T443-V000 T443-C100	FSF0408S0	-	2		

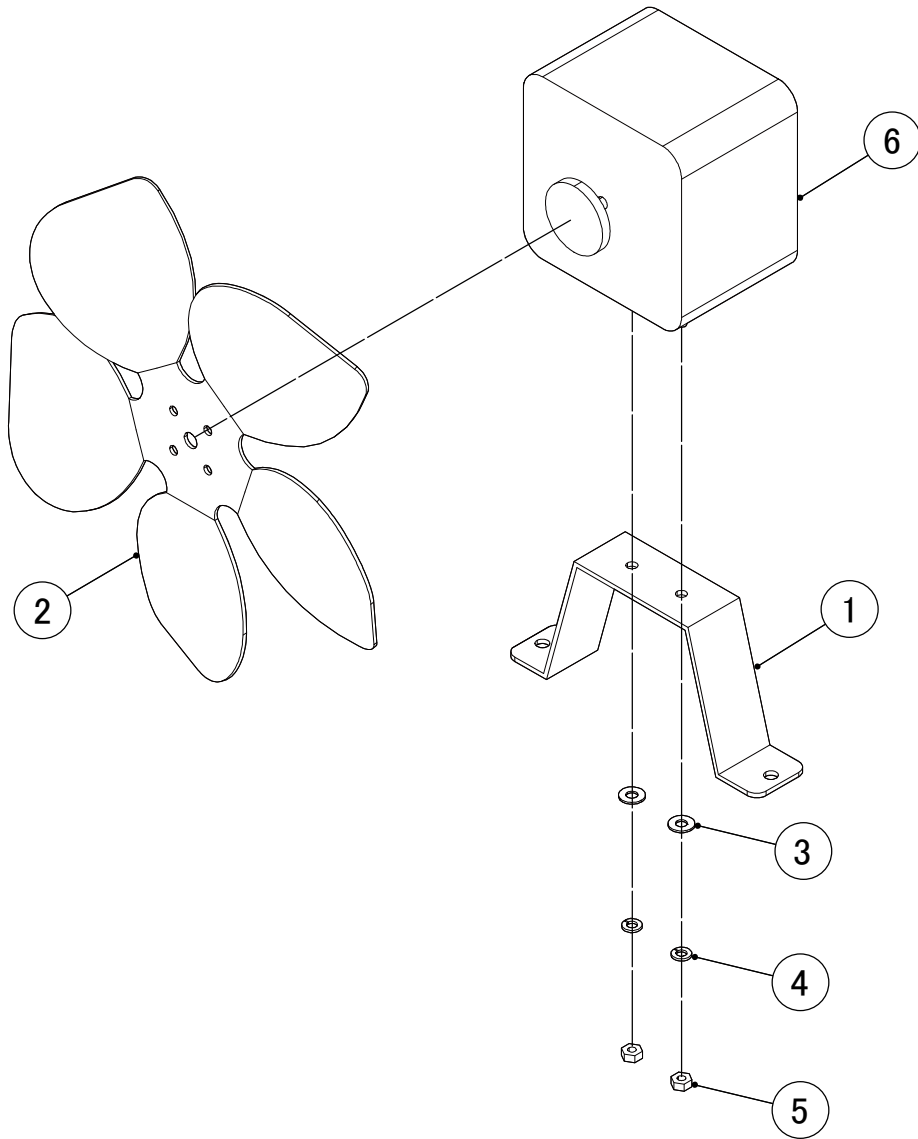

MODEL: **FT-128MC(-S)**

TITLE: **H. FAN MOTOR AY**

INDEX NO.	DESCRIPTION	MATERIAL OR MODEL NUMBER	PART NUMBER	REQ'D NUMBER			
				P-1 Q-0	Q-1 and later		
1	BRACKET - FM		4R4476M01	1	1		
2	FAN BLADE		P00006-01	1	1		
3	FLAT WASHER		FWPL04S0	2	2		
4	SPRING WASHER		FWSP04S0	2	2		
5	NUT		FNH104S0	2	2		
6	FAN MOTOR		4R5617G02	1	1		

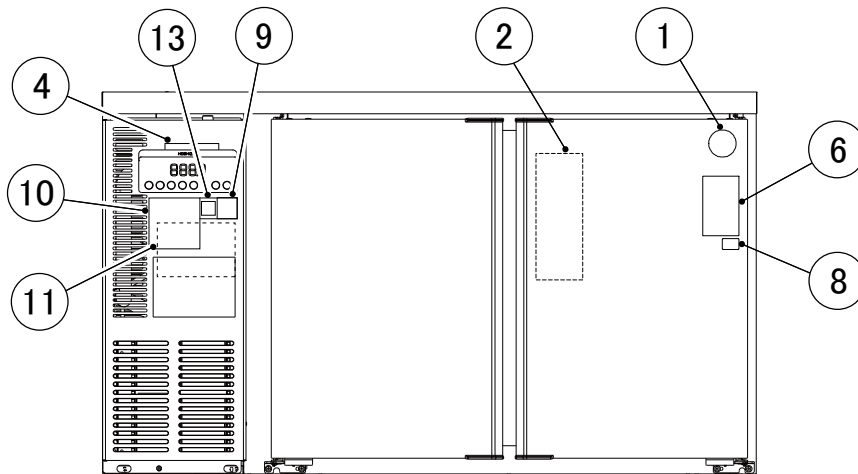
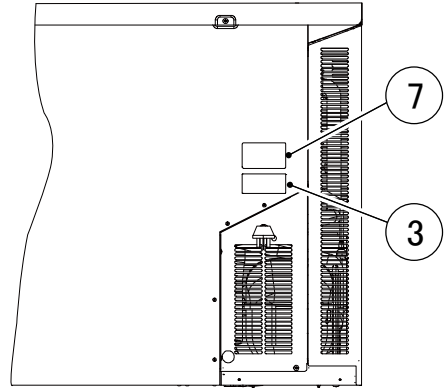
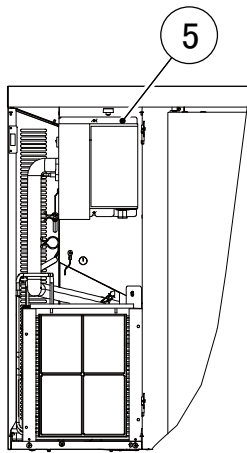

NAME PLATE

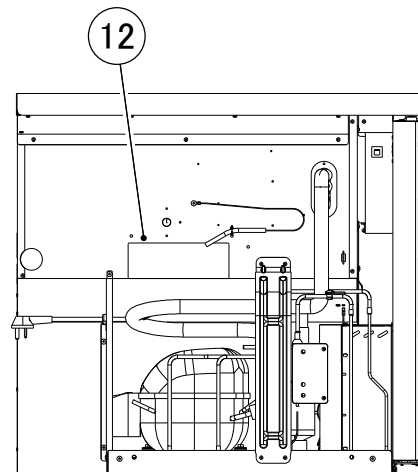
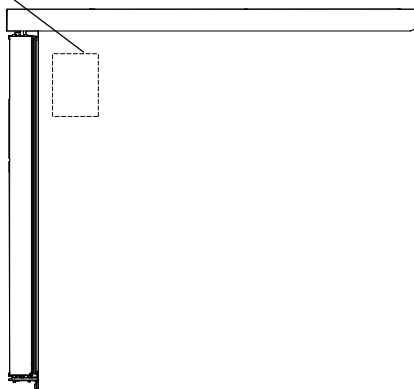

MODEL: **FT-128MC(-S)**TITLE: **L. LABEL LOCATION**

INDEX NO.	DESCRIPTION	MATERIAL OR MODEL NUMBER	PART NUMBER	REQ'D NUMBER			
				P-1 Q-0	Q-1 and later		
1	CHARACTER LABEL - PENGUIN		475552L01	1	1		
2	INSTRUCTION LABEL	T443	375467L01	1	1		
		T443-V000 T443-C100	375667L01	-	1		
3	PL LABEL-ELECTRIC SHOCK	T443	473939L01	1	1		
		T443-V000 T443-C100	474438L01	-	1		
4	LABEL - FREEZER	T443	479649L01	1	1		
		T443-V000 T443-C100	447056-01	-	1		
5	WIRING LABEL	T443	3C1112L01	1	1		
		T443-V000	3C1291L01	-	1		
		T443-C100	3C2075L01	-	1		
6	LABEL - ENERGY	T443	1C0777L14	1	1		
		T443-V000	292088L14	-	1		
7	CAUTION LABEL/CYCLOPENTANE	T443	481523L01	1	1		
		T443-V000 T443-C100	381437L01	-	1		
8	LABEL-SDoC	T443	486283L01	1	1		
9	LABEL - HACCP	T443-V000 T443-C100	476519L01	-	1		
10	LABEL - ADVISORY	T443-V000 T443-C100	399626L01	-	1		
11	CAUTION LABEL - FIRE A	T443-V000 T443-C100	3J0417L01	-	1		
12	CAUTION LABEL - FIRE B	T443-V000 T443-C100	3J0418L01	-	1		
13	LABEL QR - CODE	T443-V000	491998L01	-	1		

FT-128MC  
FT-128MC-S

M. ACCESSORIES

(P-1) and later

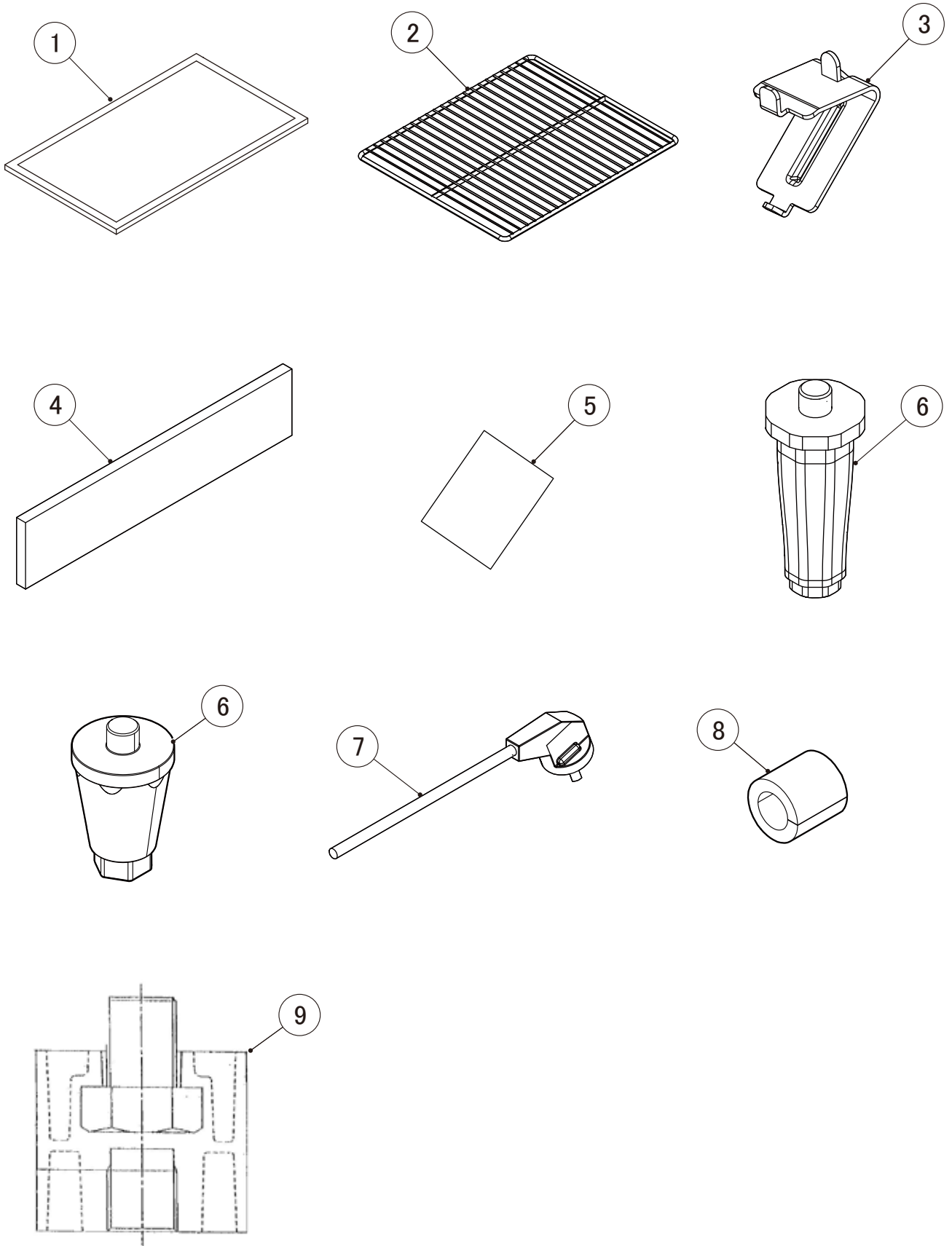

MODEL: **FT-128MC(-S)**TITLE: **M.ACCESSORIES**

INDEX NO.	DESCRIPTION	MATERIAL OR MODEL NUMBER	PART NUMBER	REQ'D NUMBER			
				P-1 Q-0	Q-1 Q-2	Q-3 and later	
1	INSTRUCTIONS MANUAL		L1T430***	1	1	1	
		T443-V000	L1S174191	-	1	1	
2	SHELF E	T443	3S3016G05	2	2	2	
		T443-V000 T443-C100		-	4	4	
3	CLIP-SHELF	T443	428957-01	8	8	8	
		T443-V000 T443-C100		-	16	16	
4	PROTECTOR		4R5783P01	2	2	2	
5	CERTIFICATE	T443	478863L01	1	1	1	
6	LEG	(S-22944) T443-V000	P05012-01	-	4	4	
		T443-C100	P05012-01	-	4	-	
			P04879-01	-	-	4	
7	POWER CORD	T443-V000	P02795-01	-	1	1	
8	HOLDER - SHELF	T443-C100	4R6243Z01	-	10	10	
9	LEG	T443-C100	446980-01	-	-	4	