



HOSHIZAKI

CERTIFICATION



HACCP International



ISO9001



Compliant with
IEC60335-2-89 Standard

FT-128MC-S UNDERCOUNTER FREEZER



Key Features



Lower running cost



Powerful cooling
performance



Self Closing Door



Removal door gaskets

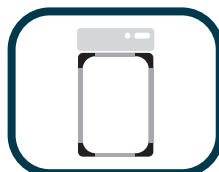

Round Interior Corners



Large and clear display



Drainage-Free Design



LED lighting



Dimensions & Specifications

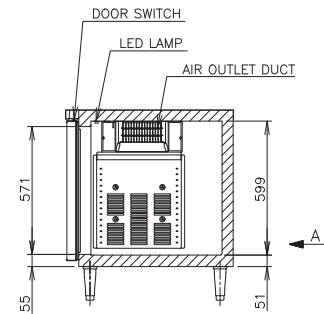
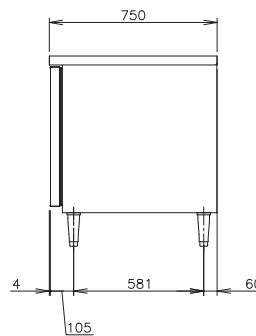
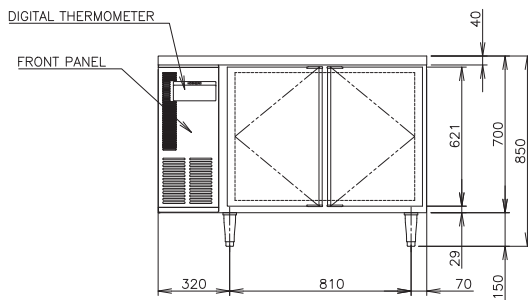
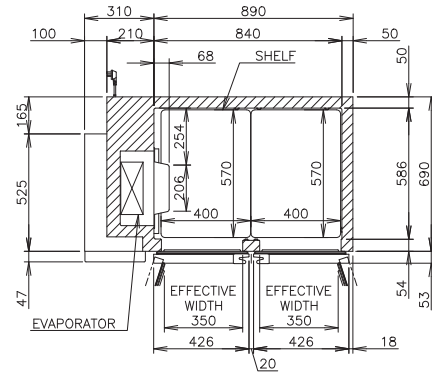
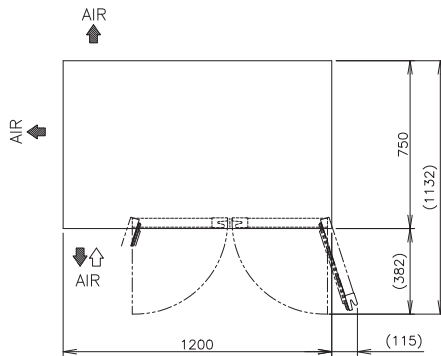
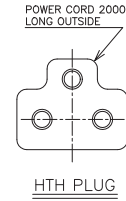
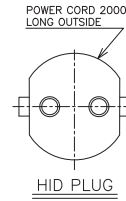
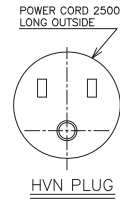
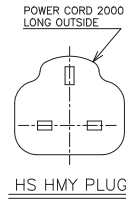
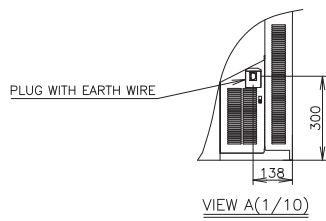

| | |
|-----------------------------|---|
| MODEL | FT-128MC-S |
| POWER SUPPLY | 1 Phase 220-240V 50Hz Capacity: 0.63kVA (2.9A) |
| ELECTRIC CONSUMPTION | 5.37kWh/day |
| TEMPERATURE CONTROL | -25 to -7°C |
| STORAGE CAPACITY | 310L |
| WEIGHT | Net: 78kg (Gross: Approx. 90kg) |
| OUTSIDE DIMENSIONS | 1200mm(W)× 750mm(D)×850(-880)mm(H) |
| PACKAGE | Carton: 1265mm(W)×830mm(D)×845mm(H) |
| NUMBER OF SHELVES | 4pcs |
| REFRIGERANT | R290 |
| OPERATING CONDITIONS | Ambient Temperature: 5 - 38°C, Voltage Range: Rated Voltage ±6% |



HOSHIZAKI

HOSHIZAKI (THAILAND) LIMITED

No. 99 CP Tower North Park building 9th Floor, Zone D1 Soi Ngamwongwan 47 Intersection 42, Thung Song Hong Subdistrict, Lak Si District, Bangkok 10210 Thailand
 TEL +66 2 005 9980 FAX +66 2 516 2646
<https://hoshizaki-sea.com/>

