



HOSHIZAKI

CERTIFICATION



HACCP International



ISO9001



Compliant with IEC60335-2-89 Standard

HF-78MC-S-ST UPRIGHT BAKERY FREEZER



Key Features



Lower running cost



Powerful cooling performance



Self Closing Door



Removal door gaskets



Round Interior Corners



Large and clear display



Drainage-Free Design



Food Guard Shelf



Dimensions & Specifications

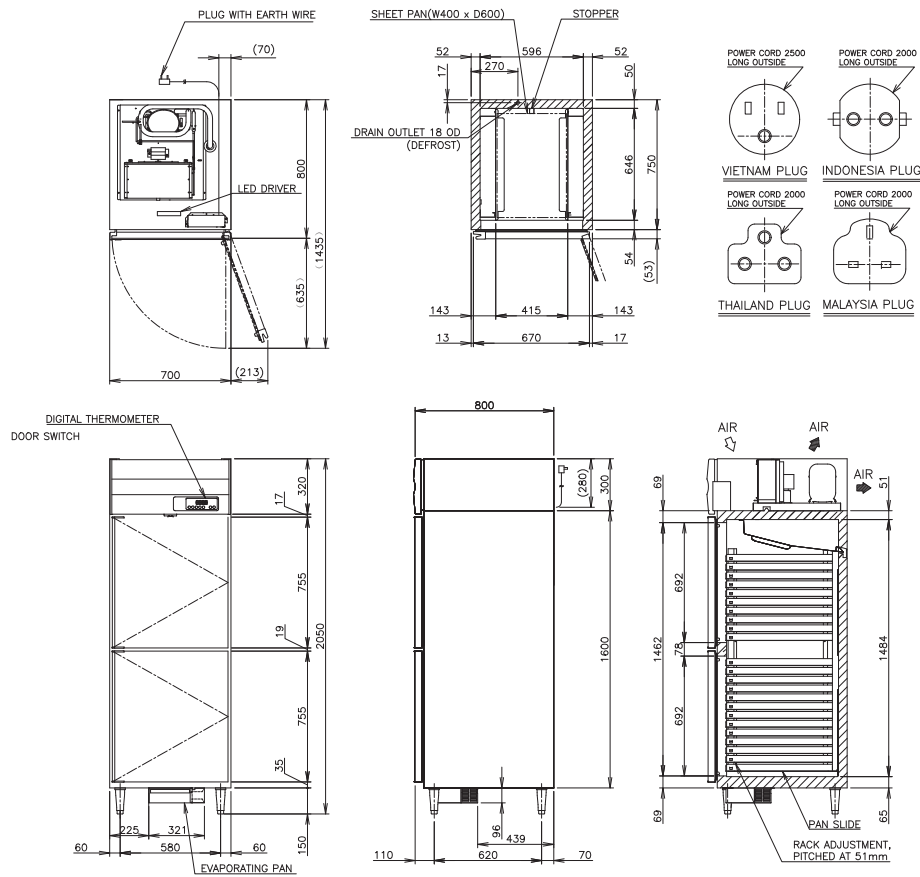

MODEL	HF-78MC-S-ST
POWER SUPPLY	1 Phase 220-240V 50Hz Capacity: 1.11kVA (5.10A)
ELECTRIC CONSUMPTION	451W
TEMPERATURE CONTROL	-25 to -7°C
STORAGE CAPACITY	567L
WEIGHT	Net: 102kg (Gross: Approx. 124kg)
OUTSIDE DIMENSIONS	700mm(W)× 800mm(D)×2050(-2080)mm(H)
PACKAGE	Carton(Wooden Pallet): 760mm(W)×900mm(D)×2075mm(H)
PITCHED (W400 x D600)	51mm (Max: Upper 10 Tiers, Lower 13 Tiers)
ACCESSORY	Bakery tray is not included
REFRIGERANT	R290
OPERATING CONDITIONS	Ambient Temperature: 5 - 38°C, Voltage Range: Rated Voltage ±6%



HOSHIZAKI

PT. HOSHIZAKI INDONESIA

