



HOSHIZAKI

CERTIFICATION



HACCP International



ISO9001



Compliant with IEC60335-2-89 Standard

HR-128MC-S-ST

UPRIGHT BAKERY REFRIGERATOR



Key Features



Lower running cost



Powerful cooling performance



Self Closing Door



Removal door gaskets

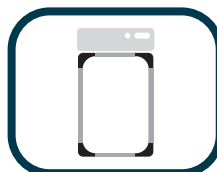

Round Interior Corners



Large and clear display



Drainage-Free Design



Food Guard Shelf



Dimensions & Specifications

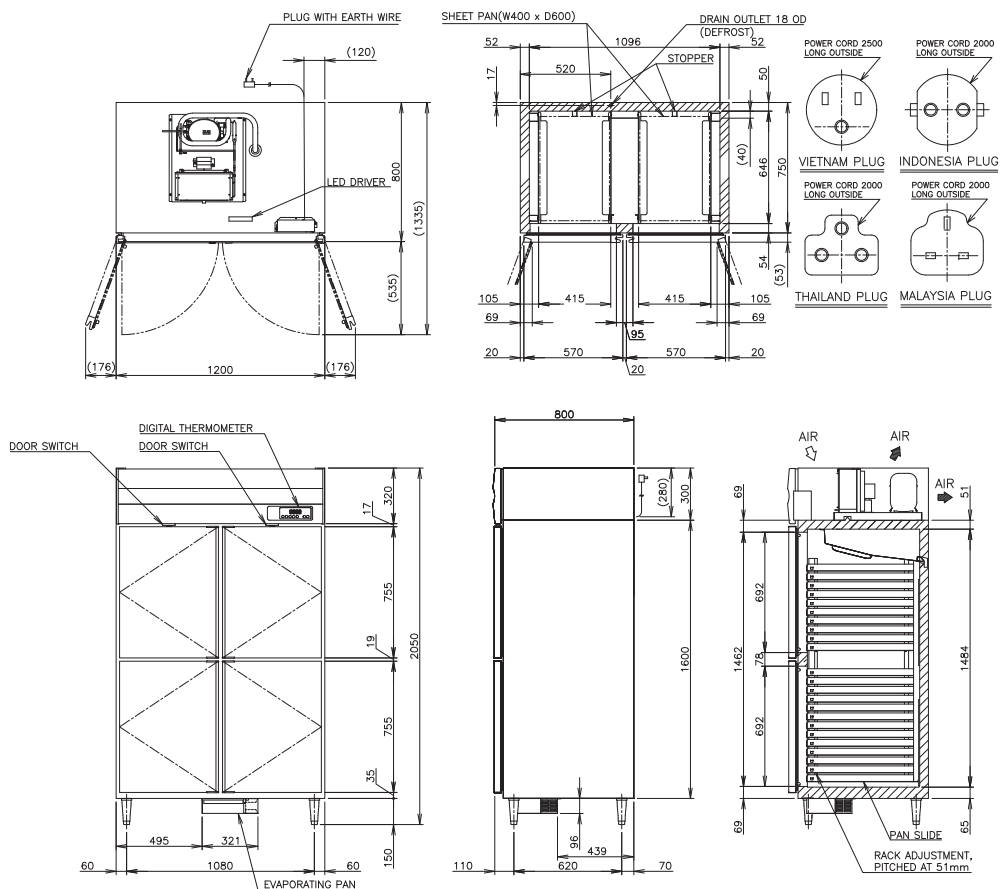

| | |
|------------------------------|---|
| MODEL | HR-128MC-S-ST |
| POWER SUPPLY | 1 Phase 220-240V 50Hz Capacity: 0.63kVA (2.90A) |
| ELECTRIC CONSUMPTION | 429W |
| TEMPERATURE CONTROL | -6 to 12°C |
| STORAGE CAPACITY | 1043L |
| WEIGHT | Net: 132kg (Gross: Approx. 161kg) |
| OUTSIDE DIMENSIONS | 1200mm(W)× 800mm(D)×2050(-2080)mm(H) |
| PACKAGE | Carton(Wooden Pallet): 1260mm(W)×900mm(D)×2075mm(H) |
| PITCHED (W400 x D600) | 51mm (Max: Upper 10 Tiers, Lower 13 Tiers) |
| ACCESSORY | Bakery tray is not included |
| REFRIGERANT | R290 |
| OPERATING CONDITIONS | Ambient Temperature: 5 - 38°C, Voltage Range: Rated Voltage ±6% |



HOSHIZAKI

PT. HOSHIZAKI INDONESIA

