



# HOSHIZAKI

## CERTIFICATION



HACCP International



ISO9001



Compliant with IEC60335-2-89 Standard

## HR-76MC-S UPRIGHT REFRIGERATOR



### Key Features



Lower running cost



Powerful cooling performance



Self Closing Door



Removal door gaskets



Food Guard Shelf



Round Interior Corners



Large and clear display



Drainage-Free Design



LED lighting



# Dimensions & Specifications

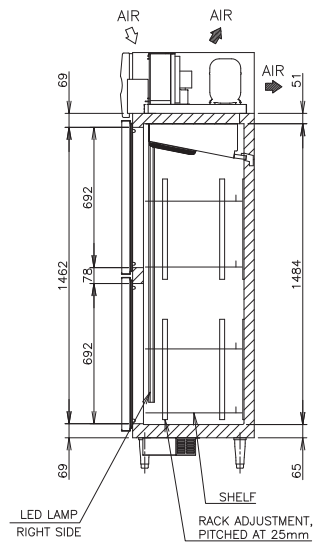
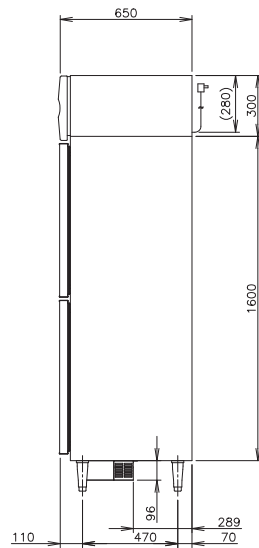
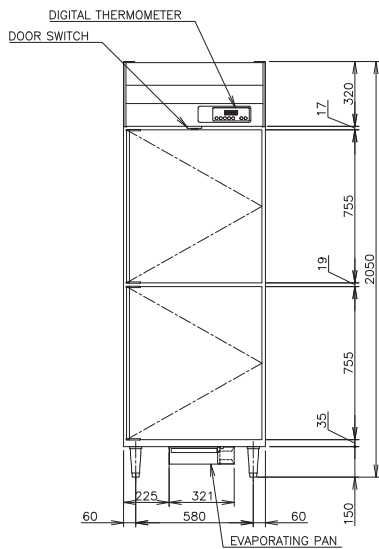
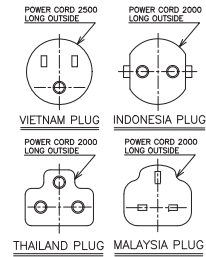
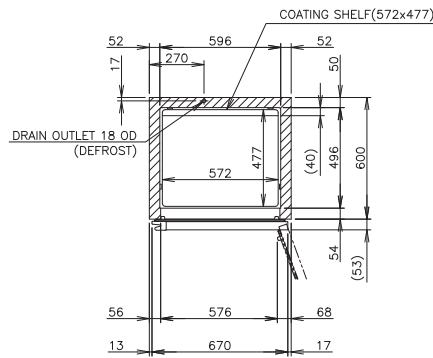
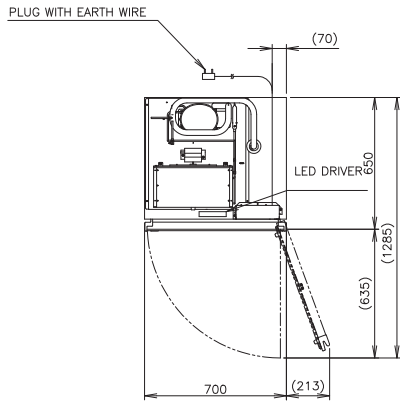

<b>MODEL</b>	<b>HR-76MC-S</b>
<b>POWER SUPPLY</b>	1 Phase 220-240V 50Hz Capacity: 0.63kVA (2.90A)
<b>ELECTRIC CONSUMPTION</b>	416W
<b>TEMPERATURE CONTROL</b>	-6 to 12°C
<b>STORAGE CAPACITY</b>	440L
<b>WEIGHT</b>	null
<b>OUTSIDE DIMENSIONS</b>	700mm(W)× 650mm(D)×2050(-2080)mm(H)
<b>PACKAGE</b>	Carton(Wooden Pallet): 760mm(W)×750mm(D)×2075mm(H)
<b>NUMBER OF SHELVES</b>	4
<b>REFRIGERANT</b>	R290
<b>OPERATING CONDITIONS</b>	Ambient Temperature: 5 - 38°C, Voltage Range: Rated Voltage ±6%



# HOSHIZAKI

**HOSHIZAKI MALAYSIA SDN. BHD.**

No. 12, Jalan Penyajak U1/45B. Hicom-Glenmarie Industrial Park, 40150 Shah Alam, Selangor

TEL (+60) 3 5569 8023 <https://hoshizaki.com.my/>

