



# HOSHIZAKI

## CERTIFICATION



HACCP International



ISO9001



Compliant with IEC60335-2-89 Standard

## RT-156MC-SSG

### UNDERCOUNTER SLIDING GLASS DOOR REFRIGERATOR



### Key Features



Lower running cost



Powerful cooling performance

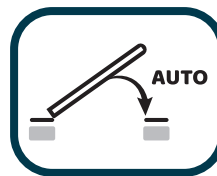

Self Closing Door



Removal door gaskets

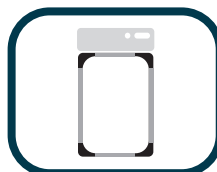

Round Interior Corners



Large and clear display



Drainage-Free Design



LED lighting



# Dimensions & Specifications

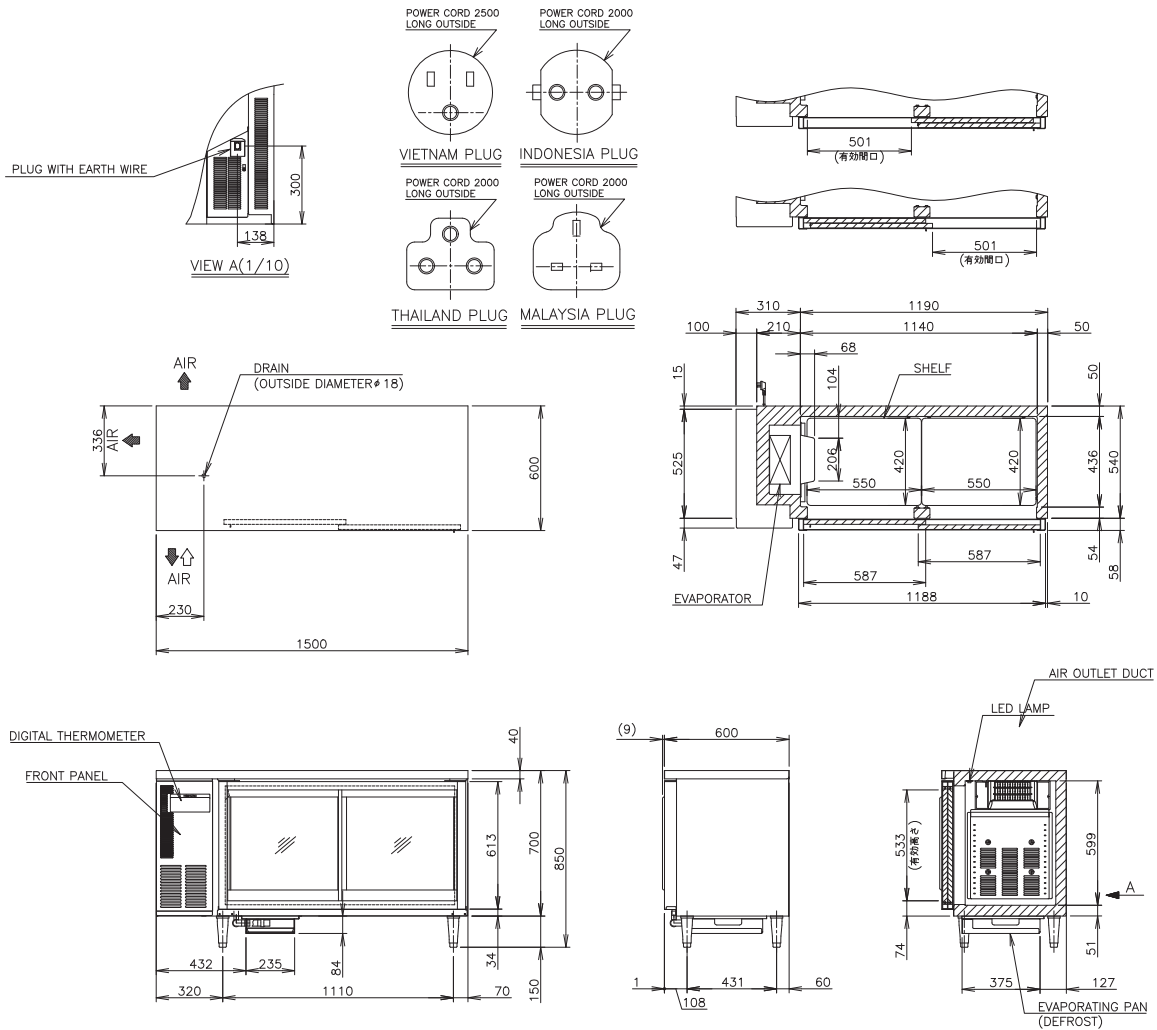

MODEL	RT-156MC-SSG
POWER SUPPLY	1 Phase 220-240V 50Hz Capacity: 0.41kVA (1.86A)
ELECTRIC CONSUMPTION	274W
TEMPERATURE CONTROL	-2 to 12°C
STORAGE CAPACITY	322L
WEIGHT	Net: 98kg (Gross: Approx. 110kg)
OUTSIDE DIMENSIONS	1500mm(W)× 600mm(D)×850(-880)mm(H)
PACKAGE	Carton: 1565mm(W)×680mm(D)×845mm(H)
NUMBER OF SHELVES	4
REFRIGERANT	R290
OPERATING CONDITIONS	Ambient Temperature: 5 - 38°C, Voltage Range: Rated Voltage ±6%



# HOSHIZAKI

## HOSHIZAKI (THAILAND) LIMITED

No. 99 CP Tower North Park building 9th Floor, Zone D1 Soi Ngamwongwan 47 Intersection 42, Thung Song Hong Subdistrict, Lak Si District, Bangkok 10210 Thailand  
 TEL +66 2 005 9980 FAX +66 2 516 2646  
<https://hoshizaki-sea.com/>

